

Hassas Yüksek Devir CNC Döner Punta

Precision High R.P.M. CNC Live Center

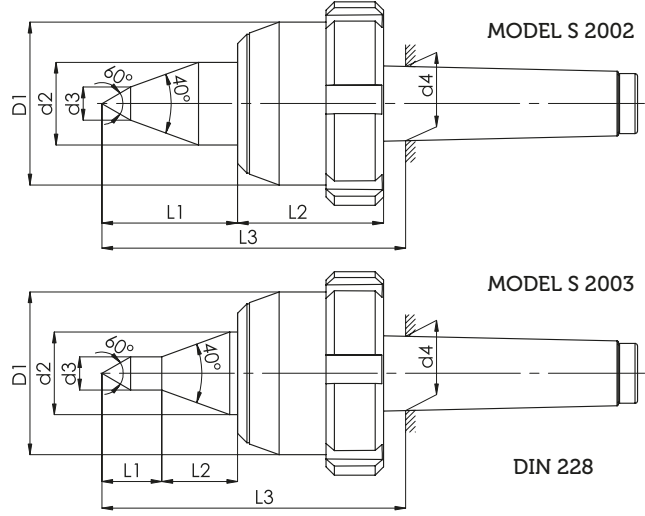

MODEL		2002		2003	
Mors Koniği / Morse conic	MK	4	5	4	5
Ölçüler mm Dimensions mm	D1	68	78	68	78
	d2	34.50	43.50	34.50	43.50
	d3	14	14	14	14
	d4	31,267	44,399	31,367	44,399
	L1	56	67	25	25
	L2	63	77	31	42
	L3	125	150	125	150
Uç Salgısı / Center Runout	Max	0.005	0.005	0.005	0.005
Ağırlık / Weight	kg.	3,5	5	3,5	5
Sipariş Kodu / Order Code		SC40	SC50	SC70	SC80

MODEL 2002 - 2003

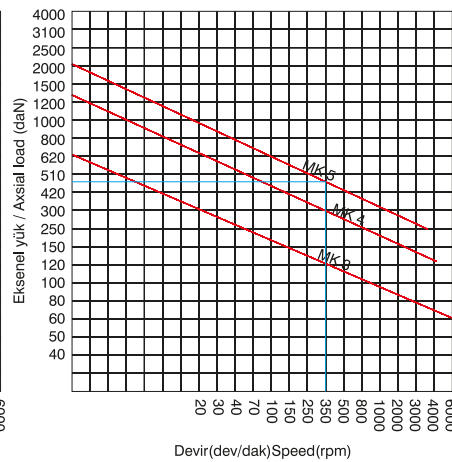
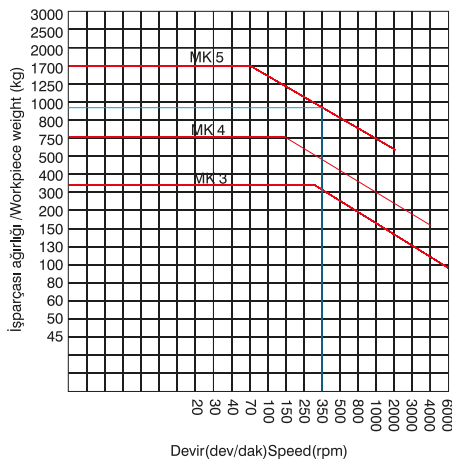

Örnek: 350Dev/Dak. ile dönen MK5 puntanın taşıya bileceği yük değeri
Radyal yük: 935 kg
eksenel yük: 475 daN

Example: load value that rotary MK5 center could carry with 350 revolution /min
Radial load: 935 Kg
Axial load: 475 daN