

Hassas CNC Döner Punta

Precision CNC Live Center

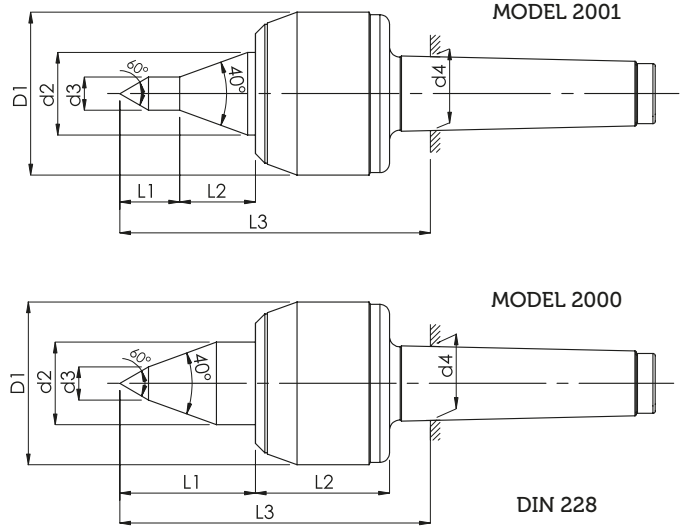

MODEL		2000			2001		
Mors Koniği / Morse conic	MK	3	4	5	3	4	5
Ölçüler mm Dimensions mm	D1	58	68	78	58	68	78
	d2	24,5	34,5	43,5	24,5	34,5	43,5
	d3	9	14	14	9	14	14
	d4	23,235	31,267	44,399	23,235	31,267	44,399
	L1	43	57	68	15	25	25
	L2	51	56	69	28	32	44
	L3	102	123	148	107	121	148
Uç Salgısı / Center Runout	Max	0,005	0,005	0,005	0,005	0,005	0,005
Ağırlık / Weight	kg.	1,5	2,5	4,5	1,5	2,5	4
Sipariş Kodu / Order Code		C30	C40	C50	C60	C70	C80

MODEL 2000 - 2001

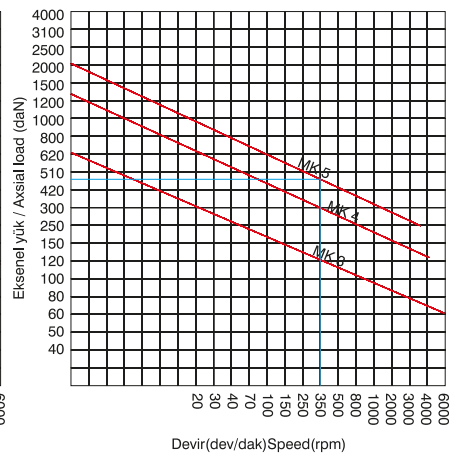
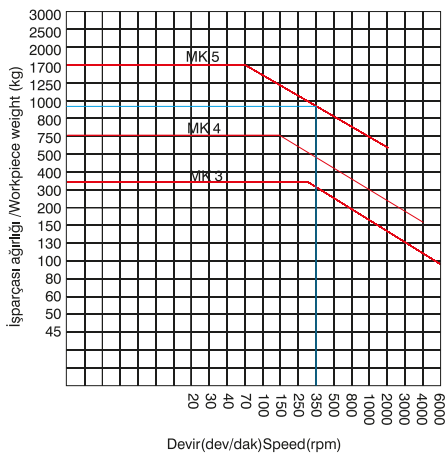

Örnek: 350 Dev/Dak. ile dönen MK5 puntanın taşıya bileceği yük değeri
Radial yük: 935 kg
eksenel yük: 475 daN

Example: load value that rotary MK5 center could carry with 350 revolution /min
Radial load: 935 kg
Axial load: 475 daN